

HO Scale



P.R.R. Baggage Building # 1

Kit Basics:

This kit consists of laser-cut wood parts. Some of the parts are backed with a peel and stick coating to ease assembly. To apply these parts simply remove the backing sheet from the part and press into place. The peel and stick adhesive allows the part locations to be adjusted slightly when first applied, but will set up to a permanent bond in a few hours.

Components are held on the larger sheets with small tabs. Use a sharp knife or razor to remove the parts by cutting through the tabs. We recommend you remove the parts as you use them. It's easier to keep track of them this way.

You will need a few basic tools and supplies such as a sharp hobby knife, a ruler, and masking tape. For gluing, we use white glue (Elmer's or similar) for wood-to-wood joints. A gap filling CA ("Super Glue") can also be used. It can be helpful to use bits of masking tape to hold the corners together while the glue dries.

Painting and Weathering tips:

We find it easier to paint many of the parts before or during assembly. If you choose to use water based paints, make sure you use a solvent based primer (automotive primer will work) to seal the wood. This will minimize the wood warping.

For an aged look, lightly dry brushing a lighter or darker color onto your original base coat will give your kit a nice weathered look. The heavier the dry brushing, the more of an aged look you will achieve. This technique can also be used on the roofing shingles.

Before you begin:

We strongly recommend that you take a few minutes to read through the instructions and diagrams to familiarize yourself with all of the parts before beginning construction. We also recommend dry fitting pieces before gluing them in place to help prevent assembly mistakes.

1

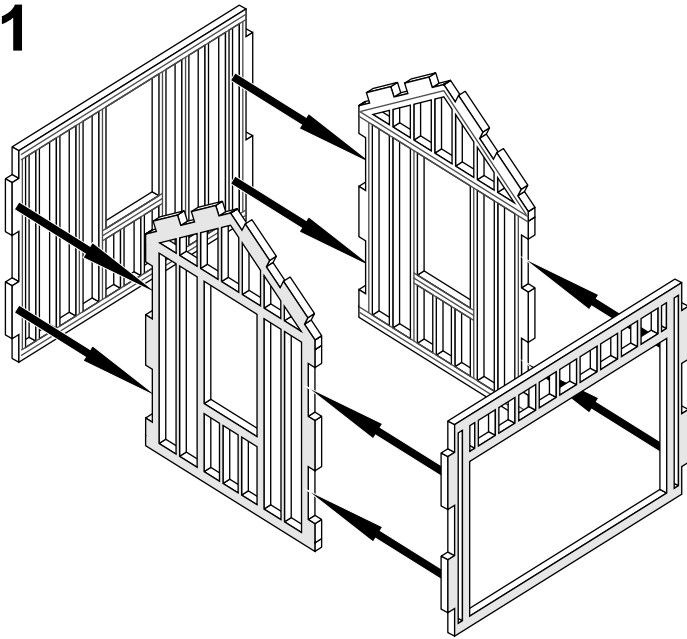

Constructing the inner framing:

1) We'll start with construction of the inner framed walls. Locate the four sections of walls that form the inner core. The wall sections have a peel-and-stick backing on them. The side with the backing will face outwards when assembling them. The four walls will glue together by aligning the tabs on the ends of each wall section. You can start by gluing the two end walls to the front and rear walls as shown. You can tape the corners of the side walls until they dry.

Wall panels:

2) Starting with the front and rear wall sections, remove the peel-and-stick backing from the core you just assembled. Carefully center the outer wall panels and press them into place. Make sure they are even with all of the edges of the core walls. Once the front and rear walls are in place, you can apply the side walls. Align the peaks of the outer panels to the ones on the core, making sure not to cover the tabs that are on top of the core walls. These side walls should overlap the front and rear walls, giving you a clean corner. A little putty can be used to fill any seams that may show. You can now paint the structure the colors of your choosing.

2

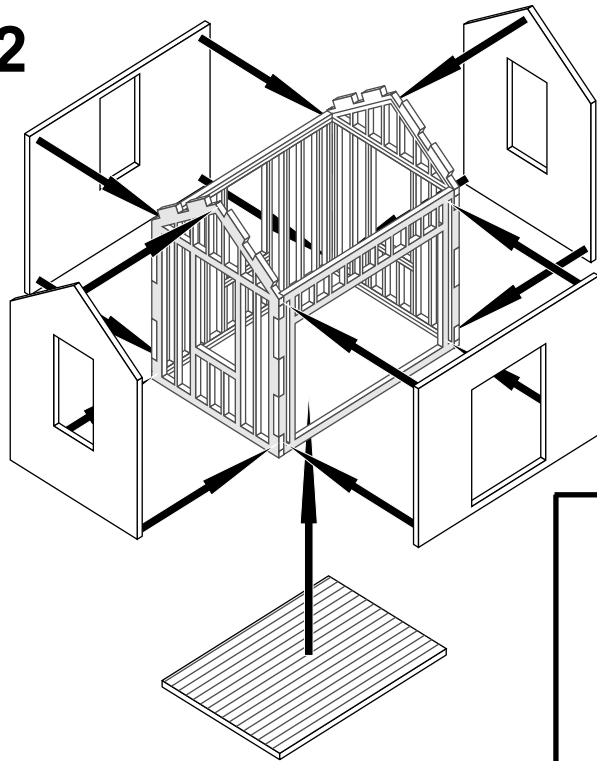

Flooring section is optional and can be glued into the underside of structure. Flooring will only be seen of the doors are displayed in an opened position.

Trim panels:

3) Locate the four trim panels on the parts sheet. Trim the panels out of the part sheet and paint them as desired. Once painted, you can begin applying them by first removing the peel-and-stick backing from them. Start by adding the front and rear wall trim panels. These will fit flush on all edges of the main wall panels. You can then apply the side trim panels. These will overlap the previous panels giving you a clean corner.

3

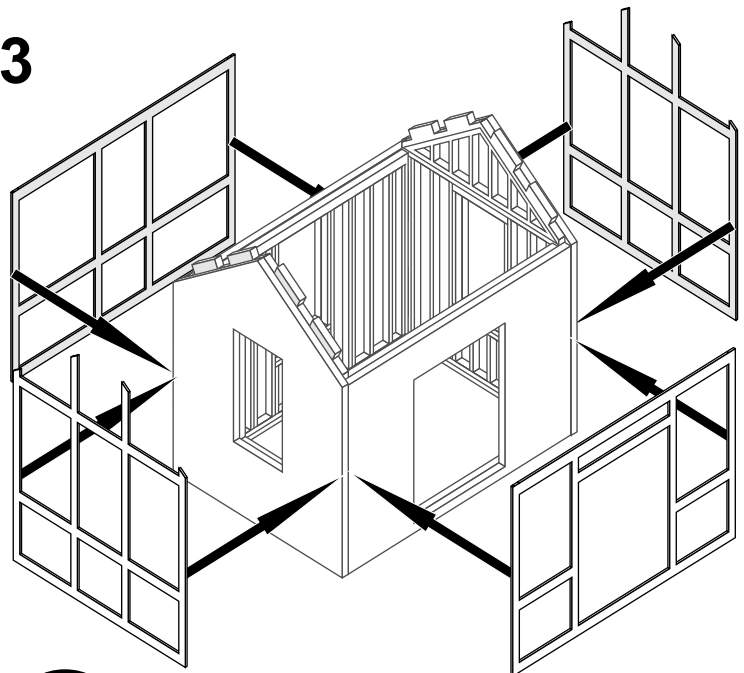

4A

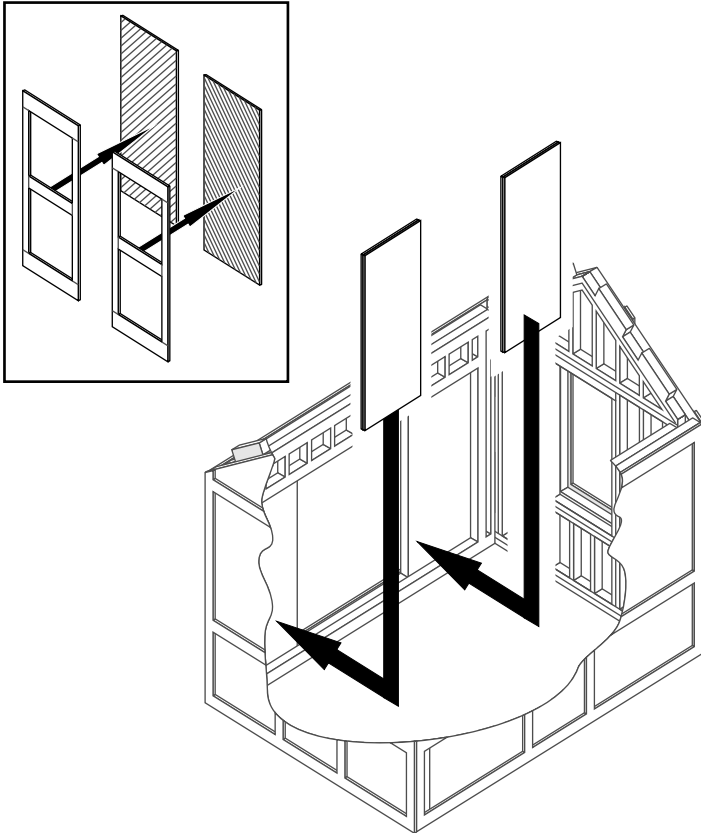

Doors:

4A) First remove the two inner door panels and the two outer panels from the parts sheet. Paint the parts before hand. Assemble the two doors by removing the peel-and-stick backing from the outer door frames and then apply them to the inner door panels as shown.

The two doors can then be inserted into their opening from inside the structure. You can choose the position of the doors as you desire. Doors on the prototype were sliding doors. There are cut outs in the inner framing that allow you to place the doors in any position.

Windows:

4B) To assemble the three window assemblies you can first cut the three windows as well as the two sections of clear glazing out of the part sheets. You can paint the window sashes as desired. These will normally match your trim color. Next remove the peel-and-stick backing from the sashes and apply the glazing to the backs of them. The windows can then be put into their openings from inside the structure as shown. The outer frames are built into the outer framing panels. The windows should fit centered into the window openings as shown.

Sub roof panels:

5) Next glue down the two sub roof panels onto the tabs on the upper side walls as shown. You can paint the underside of the roof panels prior to the installation if desired.

4B

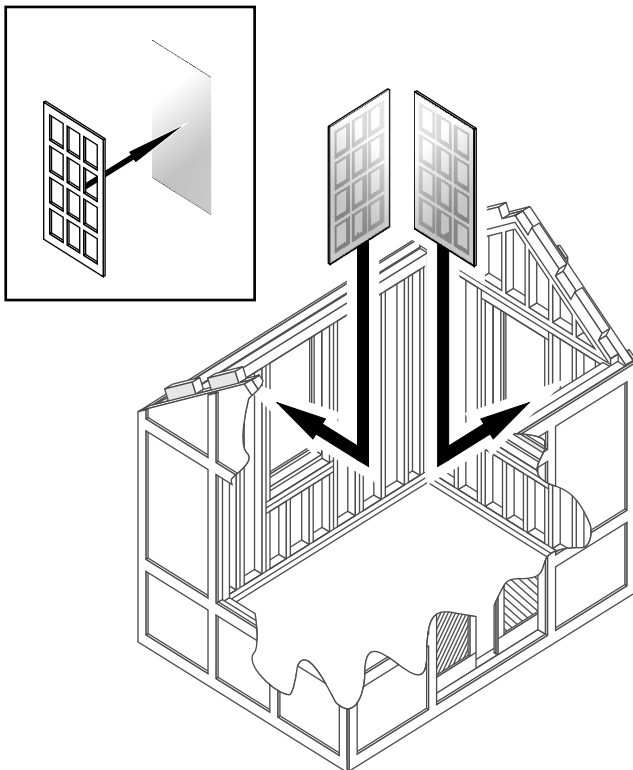

5

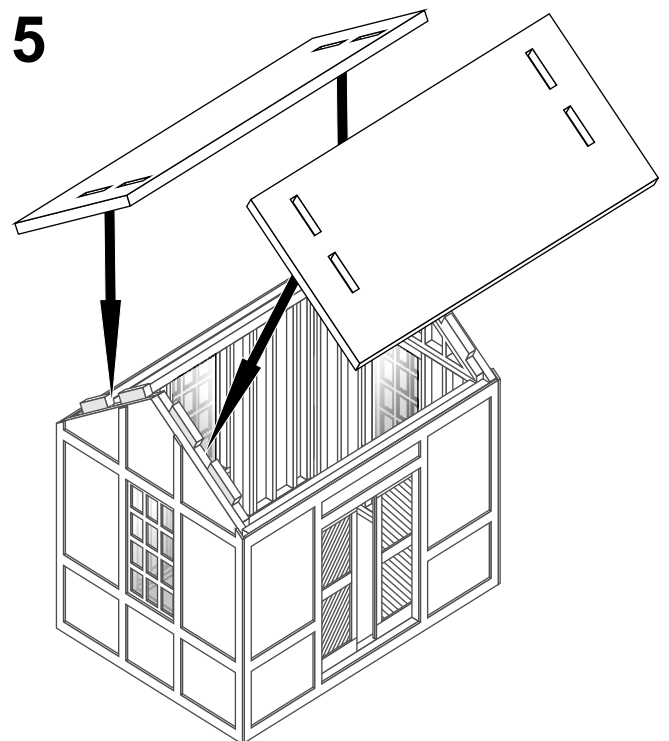

6

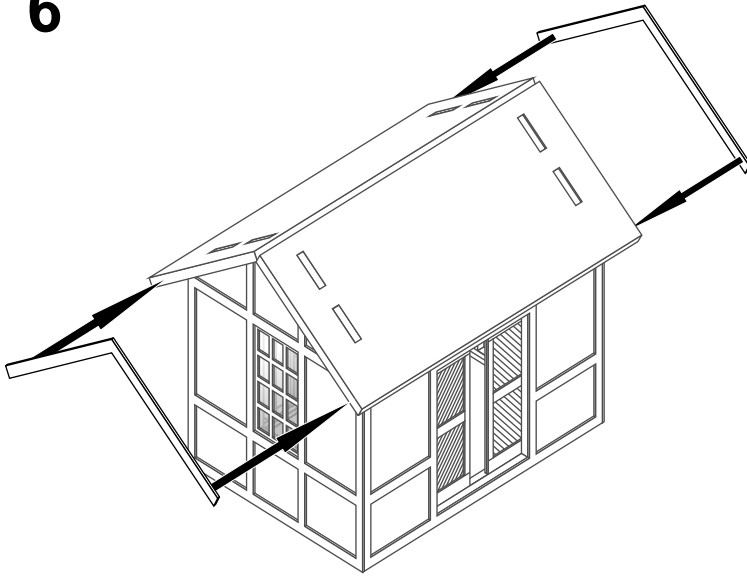

Sub roof trim:

6) Remove the two pieces of sub roof trim from the parts sheets and paint them the same color as your wall trim. To install them, remove the peel-and-stick backing from them and press them onto the side of your sub roof panels as shown. Make sure the top edges of them are aligned with the top edges of the roof panels.

Shingles:

7A) The roof shingles come to you on a sheet. You may notice that the sheet may have some light brown staining on them. These are NOT wet spots. This is caused by the laser cutting method. Your shingles will need to be painted. You can do this by painting them while still on the sheet or after you have applied them to the structure.

To apply the shingles, cut and remove several strips of shingles from the sheet. Apply a small thin layer of white glue (or glue stick) to the back of each strip and apply it to the bottom edge of each roof panel. Work your way up each panel, staggering the rows a bit as you work upward. See illustration 7A for details.

Shingle roof cap:

7B) To form the roof cap, cut a paper strip from the shingle sheet. Fold the strip down the center and glue the strip down across the peak of the structure. You can now paint and touch up the shingles as needed. You can weather the shingles by using a dry brush technique over your roof with a lighter and darker mix of your base color.

7A

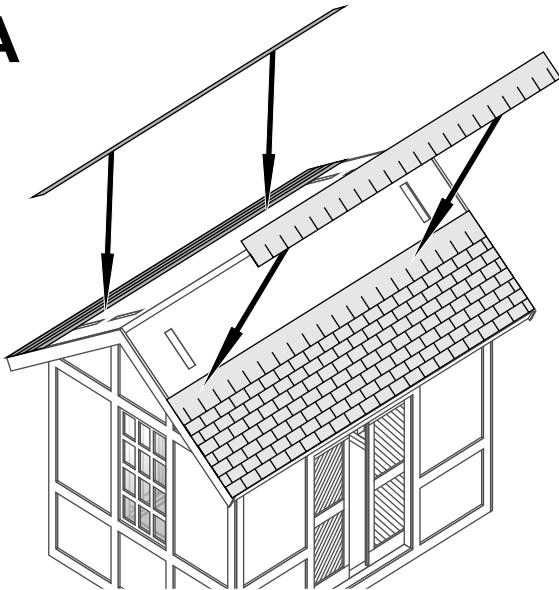

7B

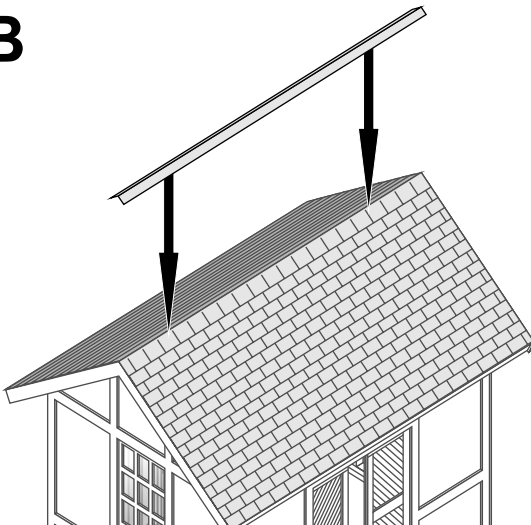

Your kit is now complete. We hope you have enjoyed this kit. If you have any questions or comments, please contact us at:

branchlinelaserart@gmail.com

To see all of our product lines, please visit our web site at:

www.branchline-trains.com

LASER - ART
Structures

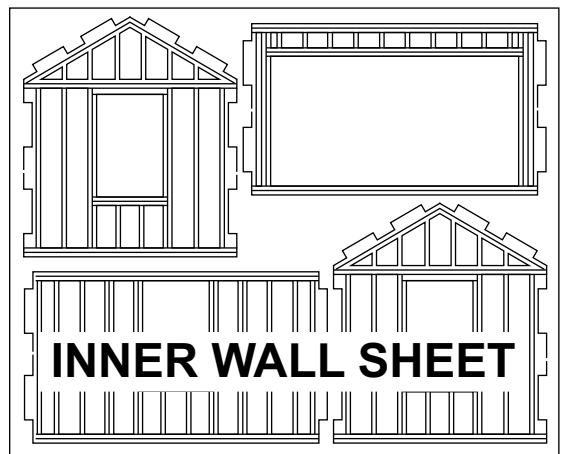
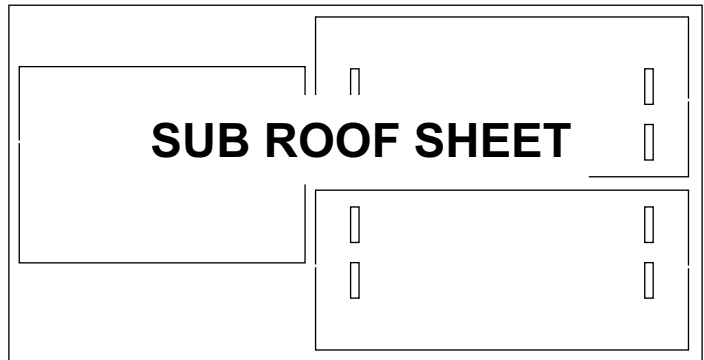
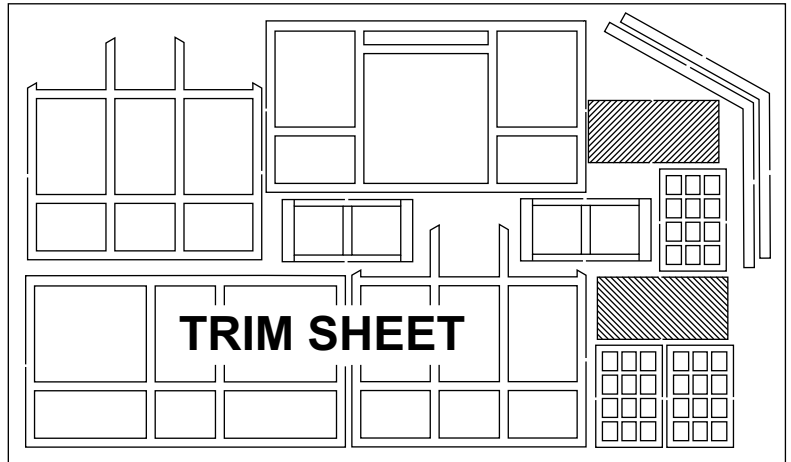
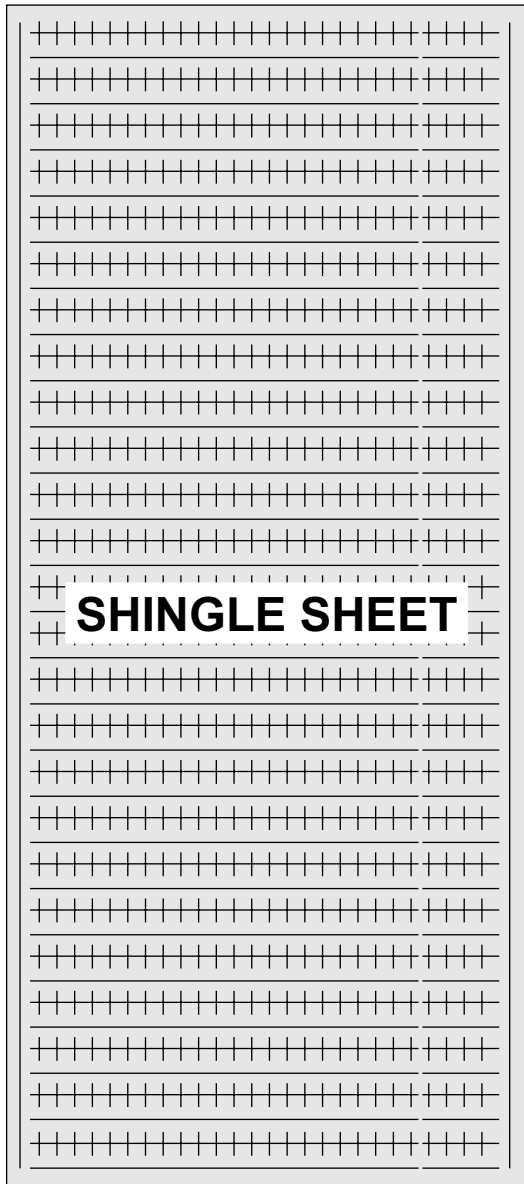
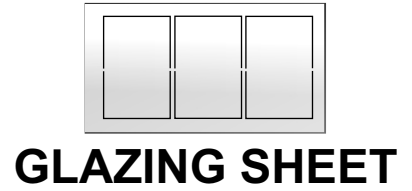
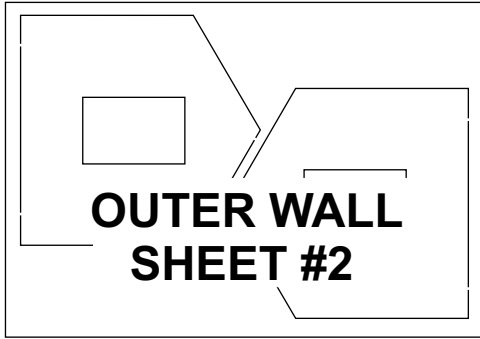
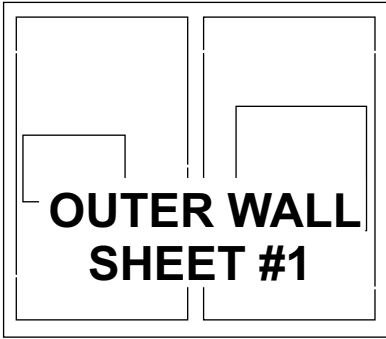

We will be happy to replace damaged or missing parts.
Please contact our customer service department at:
(860) 512-0546
Please be sure to reference the kit number, Kit scale, and
these part descriptions when asking for replacement parts.

LASER - ART
Structures

P.R.R. Baggage Building # 1

